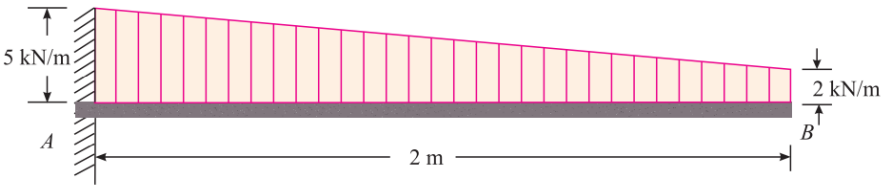
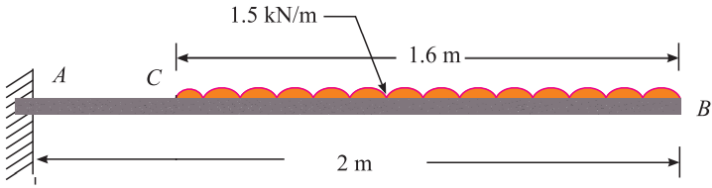
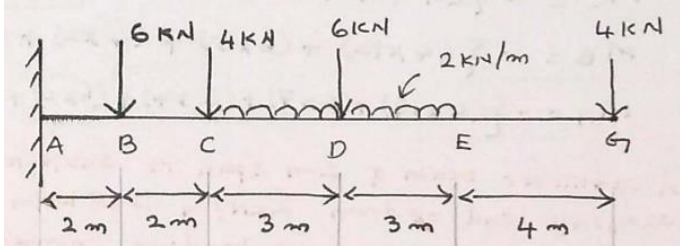

SIDDHARTH INSTITUTE OF ENGINEERING & TECHNOLOGY:: PUTTUR (AUTONOMOUS)

Siddharth Nagar, Narayanavanam Road – 517583

**QUESTION BANK (DESCRIPTIVE)****Subject with Code:** Strength of Materials (20CE0103)**Course & Branch:** B.Tech (Civil Engineering)**Year & Sem:** II/I**Regulation:** R20**UNIT – I****Shear Force and Bending Moments**

<p>1</p>	<p>(a) Define shear force and bending moment. (b) A cantilever beam of 2 m span is subjected to a gradually varying load from 2kN/m to 5 kN/m as shown in figure. Draw the shear force and bending moment diagrams for the beam.</p> 	<p>[L1][CO1] [L3][CO1]</p>	<p>[4M] [8M]</p>
<p>2</p>	<p>(a) List and explain different types of beams based on support conditions. (b) A cantilever beam AB, 2 m long carries a uniformly distributed load of 1.5 kN/m over a length of 1.6 m from the free end. Draw shear force and bending moment diagrams for the beam.</p> 	<p>[L1][CO1] [L3][CO1]</p>	<p>[6M] [6M]</p>
<p>3</p>	<p>A cantilever of 14 m span carries loads of 6 kN, 4 kN, 6 kN and 4 kN at 2 m, 4 m, 7 m and 14 m respectively from the fixed end. It also has a uniformly distributed load of 2 kN/m run for the length between 4 m and 10 m from the fixed end. Draw the shear force and bending moment diagrams.</p> 	<p>[L3][CO1]</p>	<p>[12M]</p>

<p>4</p>	<p>(a) Derive the relationship between load, shear force, and bending moment for beam. (b) A simply supported beam of span 'l' is subjected to gradually varied load as shown in the figure. Draw the shear force and bending moment diagrams.</p>	<p>[L2][CO1] [L3][CO1]</p>	<p>[6M] [6M]</p>
<p>5</p>	<p>A 10 m long simply supported beam carries two point loads of 10 kN and 6 kN at 2 m and 9 m respectively from the left end. It has a uniformly distributed load of 4 kN/m run for the length between 4 m and 7 m from the left hand end. Draw shear force and bending moment diagrams.</p>	<p>[L3][CO1]</p>	<p>[12M]</p>
<p>6</p>	<p>Draw shear force and bending moment diagrams for the beams shown in figure. Indicate the numerical values at all important sections.</p>	<p>[L3][CO1]</p>	<p>[12M]</p>
<p>7</p>	<p>A simply supported beam with over hanging ends carries transverse loads as shown in figure. If $W = 10w$, what is the overhanging length on each side, such that the bending moment at the middle of the beam, is zero? Sketch the shear force and bending moment diagrams.</p>	<p>[L4][CO1]</p>	<p>[12M]</p>
<p>8</p>	<p>(a) Find out the degree of static indeterminacy for the following beams: (i) Fixed beam (ii) Beam with hinges at both ends (iii) Simply supported beam (b) A simply supported beam subjected to couple 'M' at its mid span. Draw shear force and bending moment diagrams.</p>	<p>[L4][CO1] [L3][CO1]</p>	<p>[6M] [6M]</p>
<p>9</p>	<p>A horizontal beam AB of length 8 m is hinged at A and placed on rollers at B. The beam carries three inclined point loads as shown in figure. Draw the S.F, B.M and axial force diagrams of the beam.</p>	<p>[L3][CO1]</p>	<p>[12M]</p>

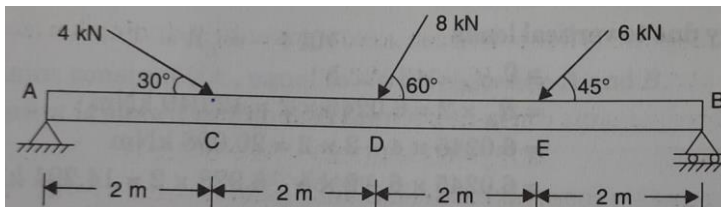
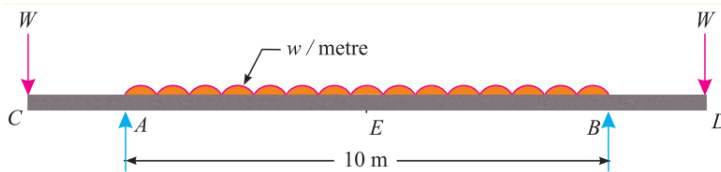
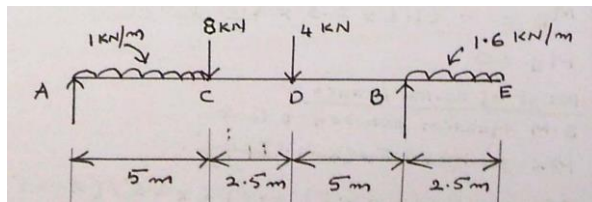
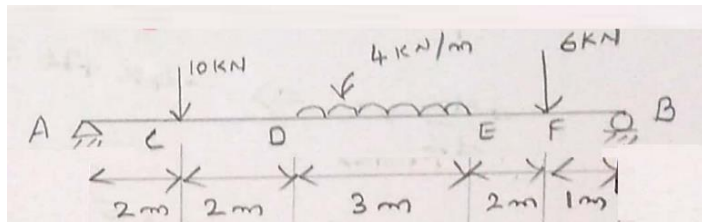
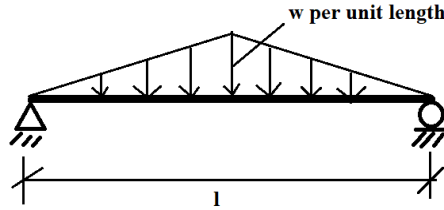

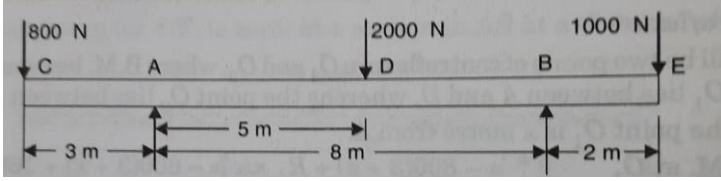
10	<p>Draw the S.F. and B.M. diagrams for the beam which is loaded as shown in figure. Determine the points of contraflexure within the span AB.</p> 	[L3][CO1]	[12M]
----	--	-----------	-------

UNIT –II

Bending Stresses in Beams & Shear Stresses in Beams

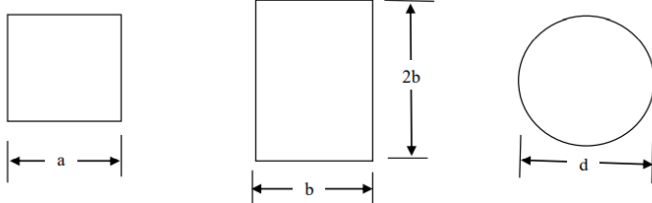
1	<p>List the assumptions made in deriving the flexure formula. Derive the equation</p> $\frac{\sigma}{y} = \frac{M}{I} = \frac{E}{R}$	[L2][CO2]	[12M]
2	<p>A timber beam of rectangular section supports a load of 20 kN uniformly distributed over a span of 3.6 m. If depth of the beam section is twice the width and maximum stress is not to exceed 7 MPa, find the dimensions of the beam section.</p>	[L4][CO2]	[12M]
3	<p>A cast iron water pipe of 500 mm inside diameter and 20 mm thick is supported over a span of 10 m. Find the maximum stress in the pipe metal, when the pipe is running full. Take density of cast iron as 70.6 kN/m³ and that of water as 9.8 kN/m³.</p>	[L4][CO2]	[12M]
4	<p>Three beams have the same length, the same allowable stress and the same bending moment. The cross-section of the beams, are a square, a rectangle with depth twice the width and a circle as shown in Figure. Find the ratios of weights of the circular and the rectangular beams with respect to the square beam.</p> 	[L5][CO2]	[12M]
5	<p>A circular log of timber has diameter 'D'. Find the dimensions of the strongest rectangular section to resist moment, one can cut from this log.</p>	[L4][CO2]	[12M]
6	<p>(a) Derive the formula for horizontal shearing stress flexural stress. (b) Draw the shear stress distribution for a rectangular section of width 'b' and depth 'd'.</p>	[L2][CO2] [L3][CO2]	[6M] [6M]
7	<p>Draw the shear stress distribution of triangular section of width 'b' and height 'h'. Prove that the maximum shear stress is 1.5 times the average shear stress.</p>	[L4][CO2]	[12M]
8	<p>A timber beam of rectangular section is simply supported at the ends and carries a point load at the centre of the beam. The maximum bending stress is 12 N/mm² and maximum shearing stress is 1 N/mm², find the ratio of the span to the depth.</p>	[L4][CO1]	[12M]
9	<p>Draw the shear stress distribution for an I section which is symmetrical about both the axis. The width of flanges being 'B' and web 'b'. The overall depth 'D' and depth of web 'd'.</p>	[L3][CO2]	[12M]
10	<p>A T – shaped cross section of a beam shown in figure is subjected to a vertical shear force of 100 kN. Calculate the shear stress at important points and draw shear stress distribution diagram. Moment of inertia about the horizontal neutral axis (I) = 113.4 x 10⁶ mm⁴.</p>	[L3][CO2]	[12M]

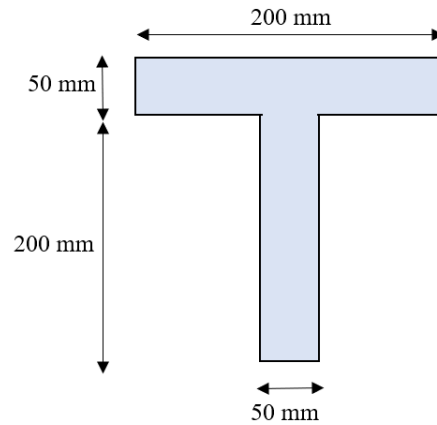

UNIT –III

Torsion on Circular Shafts & Springs

1	(a) Define the terms: Torsion, torsional rigidity and polar moment of inertia. (b) A solid shaft of 150 mm diameter is used to transmit torque. Find the maximum torque transmitted by the shaft if the maximum shear stress induced to the shaft is 45 kN/mm ² .	[L1][CO3] [L3][CO3]	[6M] [6M]
2	Derive the relation for a circular shaft when subjected to torsion as below: $\frac{T}{J} = \frac{\tau}{R} = \frac{C\theta}{L}$ Where T = torque transmitted, J = Polar moment of inertia, τ = Maximum shear stress, R = Radius of the shaft, C = Polar moment of inertia, θ = Angle of twist, and L = Length of the shaft.	[L2][CO3]	[12M]
3	(a) What are assumptions made in the derivation of shear stress produced in a circular shaft subjected to torsion? (b) Prove that the torque transmitted by a solid shaft when subjected to torsion is given by $T = \frac{\pi}{16} \tau D^3$, where D = Diameter of solid shaft and τ = Maximum shear stress.	[L1][CO3] [L2][CO3]	[4M] [8M]
4	Two shafts of the same material and same lengths are subjected to the same torque, if the first shaft is of a solid circular section and second shaft is of hollow circular section, whose internal diameter is 2/3 of the outside diameter and the maximum shear stress developed in each shaft is the same, compare the weights of the shafts.	[L4][CO3]	[12M]
5	A solid circular shaft transmits 75 kW power at 200 r.p.m. Calculate the shaft diameter, if the twist in the shaft is not to exceed 1° in 2 metres length of shaft, and shear stress is limited to 50 N/mm ² . Take C = 1 x 10 ⁵ N/mm ² .	[L3][CO3]	[12M]
6	A solid shaft is subjected to a bending moment of 2.3 kNm and a twisting moment of 3.45 kNm. Find the diameter of the shaft if the permissible tensile and shear stress for the material of the shaft are limited to 703 and 421.8 MN/m ² respectively.	[L4][CO3]	[12M]
7	A closely coiled helical spring with D as diameter of the coil and d as diameter of the wire is subjected to an axial load W. Prove that the maximum shear stress produced is equal to $\frac{8WD}{\pi d^3}$.	[L1][CO3]	[12M]
8	For a close-coiled helical spring subjected to an axial load of 300 N having 12 coils of wire diameter of 16 mm, and made with coil diameter of 250 mm, find: (i) Axial deflection; (ii) Strain energy stored; (iii) Maximum torsional shear stress in the wire.	[L2][CO3]	[12M]
9	An open coil helical spring made of 10 mm diameter wire and mean diameter of 100 mm has 12 coils, angle of helix being 15°. Determine the axial deflection and the intensities of bending and shear stresses under an axial load of 500 N. Take C as 80 GPa and E as 200 GPa.	[L3][CO3]	[12M]

10	A carriage spring is to be 600 mm long and made of 9.5 mm thick steel plates and 50 mm broad. How many plates are required to carry a load of 4.5 kN, without the stress exceeding 230 MN/m ² . What would be central deflection and the initial radius of curvature, if plates straighten under the load? E = 200 GN/m ² .	[L3][CO3]	[12M]
----	---	-----------	-------

UNIT –IV Deflections of Beams

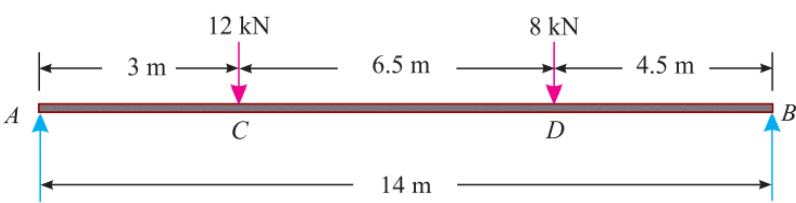
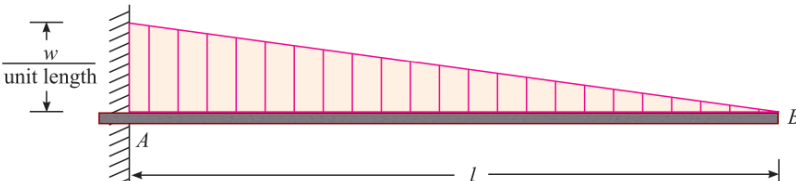
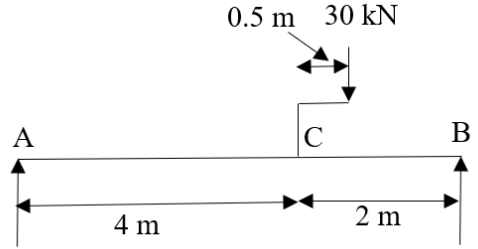
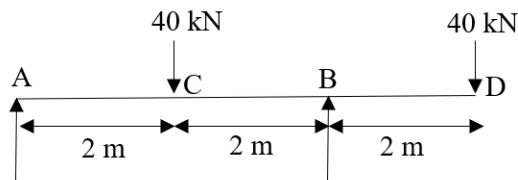
1	State the assumptions and derive the equation $M = EI \frac{d^2y}{dx^2}$.	[L2][CO4]	[12M]
2	Using double integration method determine the maximum slope and deflection for a simply supported beam subjected to uniformly distributed load throughout the length of the beam.	[L3][CO4]	[12M]
3	A timber beam of rectangular section has a span of 4.8 m and is simply supported at its ends. It is required to carry a total load of 45kN uniformly distributed over the whole span. Find the value of the breadth (b) and depth (d) of the beam, if maximum bending stress is not to exceed 7 Mpa and maximum deflection is limited to 9.5 mm. Take E for the timber as 10.5 GPa.	[L4][CO4]	[12M]
4	<p>A horizontal steel girder having uniform cross-section is 14 m long and is simply supported at its ends. It carries two concentrated loads as shown in figure. Calculate the deflections of the beam under the loads C and D. Take E = 200 GPa and I = 160 x 10⁶ mm⁴.</p> 	[L3][CO4]	[12M]
5	<p>Find slope and deflection for a cantilever beam subjected to gradually distributed load as shown in the figure at the free end B.</p> 	[L3][CO4]	[12M]
6	<p>Find the deflection at C in the beam loaded as shown in figure. Take EI = 10000 kN-m².</p> 	[31][CO4]	[12M]
7	<p>Determine the deflection under the loads in the beam shown in figure. Take flexural rigidity as EI throughout.</p> 	[L3][CO4]	[12M]
8	A beam AB of span 8 m is simply supported at the ends A and B and is loaded as shown in Figure. If E = 200 x 10 ⁶ kN/m ² and I = 120 x 10 ⁻⁶ m ⁴ determine:	[L3][CO4]	[12M]

	(i) Deflection at the mid span (ii) Maximum deflection (iii) Slope at the end A.		
9	A simply supported beam of length 'l' is carrying a uniformly distributed load of magnitude w per unit length throughout the span. Using Moment Area Method determine slope at the supports and deflection at the mid span.	[L3][CO4]	[12M]
10	A cantilever of length 2a is carrying a load of W at the free end, and another load of W at its centre as shown in the figure. Determine, by Moment Area Method, the slope and deflection of the cantilever at the free end.	[L3][CO4]	[12M]

UNIT –V

Columns & Direct and Bending Stresses

1	a) What are the assumptions made in Euler's theory? b) Find the ratio of buckling strength of a solid column to that of a hollow column of the same material and having the same cross-sectional area. The internal diameter of the hollow column is half of its external diameter. Both the columns are hinged and the same length.	[L1][CO5] [L3][CO5]	[4M] [8M]
2	a) Derive the equation of Euler's crippling load on a column when both ends of are hinged. b) An angular section 240 x 120 x 20 mm is used as 6 m long column with both ends are fixed. What is the crippling load for the column? Take $E = 210 \text{ GPa}$.	[L2][CO5] [L3][CO5]	[6M] [6M]
3	A hallow alloy tube 4 m long with external and internal diameters of 40 mm and 25 mm respectively was found to extend 4.8 mm under a tensile load of 60 kN. Find the buckling load for the tube with both ends pinned. Also find the safe load on the tube, taking a factor of safety as 5.	[L4][CO5]	[12M]
4	A bar of length 4 m when used as a simply supported beam and subjected to a udl of 30 kN/m over the whole span, deflects 15 mm at the centre. Determine the crippling loads when it is used as a column with following end conditions: (i) Both ends pin-jointed (ii) One end fixed and other end hinged (iii) Both ends fixed.	[L4][CO5]	[12M]
5	A slender pin ended aluminum column 1.8 m long and of circular cross-section is to have an outside diameter of 50 mm. Calculate the necessary internal diameter to prevent failure by buckling if the actual load applied is 13.6 kN and the critical load applied is twice the actual load. Take E for aluminum as 70 GN/m^2 .	[L4][CO5]	[12M]
6	A hollow circular column having external and internal diameters of 300 mm and 250 mm respectively carries a vertical load of 100 kN at the outer edge of the column. Calculate the maximum and minimum intensities of stress in the section.	[L3][CO5]	[12M]
7	A column 800 mm x 600 mm is subjected to an eccentric load of 60 kN as shown in figure. What are the maximum and minimum intensities of stresses in the column?	[L3][CO6]	[12M]

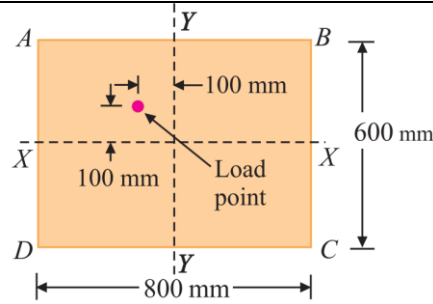

<p>8</p>	<p>(a) A rectangular section of width b and thickness d, find out limit of eccentricity and draw the kernel. (b) In a tension specimen 13 mm in diameter the line of pull is parallel to the axis of the specimen but is displaced from it. Determine the distance of the line of pull from the axis, when the maximum stress is 15% greater than the mean stress on a section normal to the axis.</p>	<p>[L2][CO6]</p>	<p>[4M]</p>
<p>9</p>	<p>A concrete dam has its upstream face vertical and a top width of 3 m. Its downstream face has a uniform batter. It stores water to a depth of 15 m with a free board of 2 m as shown in figure. The weights of water and concrete may be taken as 10 kN/m^3 and 25 kN/m^3. Calculate (a) the minimum dam width at the bottom for no tension in concrete. Neglect uplift. (b) the extreme intensities of pressure on the foundation, when reservoir is empty.</p>	<p>[L4][CO6]</p>	<p>[12M]</p>
<p>10</p>	<p>A masonry wall 5 m high and 1.8 m wide is containing water up to a height of 4 m. If the coefficient of friction between the wall and the soil is 0.6, check the stability of the wall. Take weight of the masonry and water as 22 kN/m^3 and 9.81 kN/m^3.</p>	<p>[L4][CO6]</p>	<p>[12M]</p>

